

AUTO FOCUS LENS

Image Security Masking / 48V PoC

EX-SDI PoC IR Bullet Camera



SNEP-B6623AIR



Features

- 2M CMOS Sensor (Starvis)
- 1080P @30/25fps
- EX-SDI 2.0 (Output Distance: 500 ~ 600mm) / EX-SDI 1.0 / HD-SDI
- 2.7-12mm Motorized (Auto Focus) F1.4 Lens
- 2.8-12mm Motorized(Auto Focus) F1.4 Lens (Option)
- 2.7-10mm Motorized(Auto Focus) F1.2 Lens (Option)
- Defog Function (Visibility Enhancement)
- 3D Digital Noise Reduction
- Image Security Masking
- 48V PoC
- 32 IR LEDs
- Camera Operating Indicate LED (Normal: Green, Low Power: Red, Power Down: Off)
- 1 point joint : 3axis adjustment

Dimension ※scale: NS (mm)

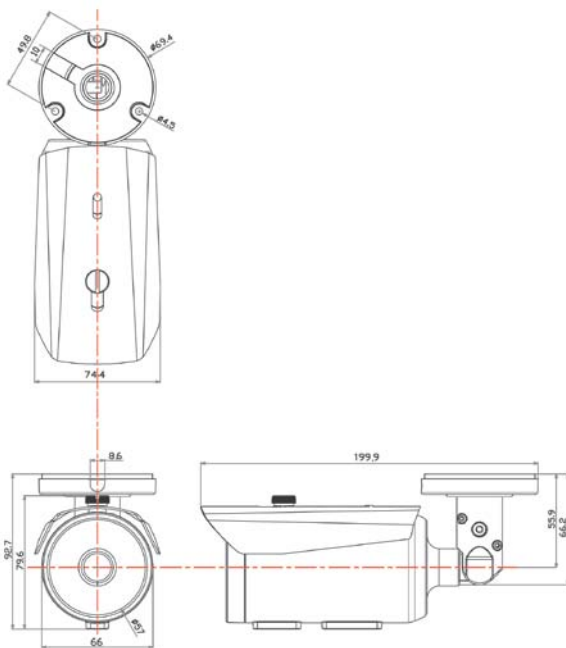

Specifications

MODEL	SNEP-B6623AIR
Image Device	1/2.8" SONY 2M CMOS (Starvis)
Total Pixels	1945(H) x 1109(V) approx. 2.16M pixels
Effective Pixels	1945(V) x 1097(V) approx. 2.13M pixels
Scanning System	Progressive
Resolution	1080P@30fps
S/N Ratio	More than 52dB(AGC OFF)
Min.Illumination	0.0 Lux @ (IR ON)
Video Output	EX-SDI 2.0 (Output Distance: 500 ~ 600mm) / EX-SDI 1.0 / HD-SDI
Electronic Shutter	NTSC : 1/30~1/30,000sec, PAL : 1/25~1/25,600sec
Lens Type	2.7-12mm Motorized (Auto Focus) F1.4 Lens / 2.8-12mm Motorized(Auto Focus) F1.4 Lens (Option) / 2.7-10mm Motorized(Auto Focus) F1.2 Lens (Option)
Iris	ELC, ALC
2Motor	AF MODE, SCANNING, ONEPUSH AF, SYNC TDN, INITIAL
Exposure	BRIGHTNESS, SHUTTER, SENS-UP, AGC
Backlight	OFF, HLC, BLC, WDR
Day & Night	AUTO, COLOR, B&W, EXTERN
Color	AWB, COLOR GAIN
DNR	OFF, LOW, MIDDLE, HIGH
Image	SHARPNESS, GAMMA, MIRROR, FLIP, ACE, DEFOG, PRIVACY
Motion	OFF, ON
System	FRAME RATE, FREQ, EX-SDI, IMAGE RANGE, LANGUAGE, RESET
Language	ENG, CHN, CHN(S), JPN, KOR
IR LED(Wavelength)	32 IR LEDs (850nm)
Operating Temp. /Storage Temp.	-10°C~+50°C(14°F~122°F) / -20°C~+60°C(-4°F~140°F)
Humidity	Less than 80% RH
Dimension(mm)	199.9×92.7

1 point joint : 3 axis adjustment

특허 (제 10-2130527호)



1 point joint (screw)

- Loosen one set screw to freely move the surveillance direction. It can be adjusted in any direction and can be easily installed by anyone.