

Super Wide Angle(150°) FIXED LENS

24Hours Color Video Surveillance / Image Security Maskingx

Ex-Sdi Mini Dome Camera

SNED-D6021F



Features

- 24Hours Color Video Surveillance
- 2M CMOS Sensor (Starvis)
- 1080P@30/25fps
- EX-SDI 2.0 (Output Distance: 500 ~ 600mm) / EX-SDI 1.0 / HD-SDI
- 2.1mm Super Wide Angle(150°) Fixed Lens
- Defog Function (Visibility Enhancement)
- 3D Digital Noise Reduction
- Image Security Masking

Dimension ※scale: NS (mm)

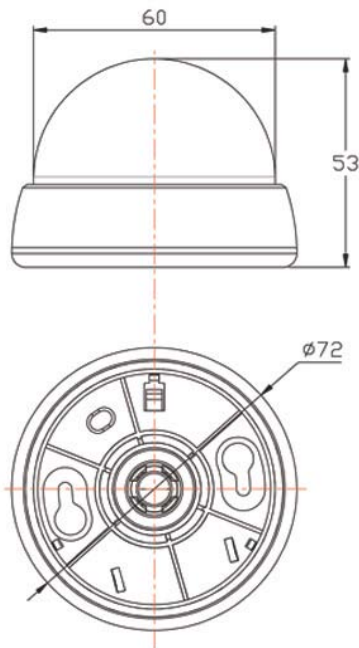

Specifications

MODEL	SNED-D6021F
Image Device	1/2.8" SONY 2M CMOS (Starvis)
Total Pixels	1945(H) x 1109(V) approx. 2.16M pixels
Effective Pixels	1945(V) x 1097(V) approx. 2.13M pixels
Scanning System	Progressive
Resolution	1080P@30/25fps
S/N Ratio	More than 52dB(AGC OFF)
Min.Illumination	0.001 Lux @ (SENSE-UP)
Video Output	EX-SDI 2.0 (Output Distance: 500 ~ 600mm) / EX-SDI 1.0 / HD-SDI
Sync. System	Internal
Electronic Shutter	NTSC : 1/30~1/30,000sec, PAL : 1/25~1/25,600sec
Lens Type	2.1mm Super Wide Angle(150°) Fixed Lens
Iris	ELC, ALC
Exposure	BRIGHTNESS, SHUTTER, SENS-UP, AGC
Backlight	OFF, HLC, BLC, WDR
Day & Night	AUTO, COLOR, B&W
Color	AWB, COLOR GAIN
DNR	OFF, LOW, MIDDLE, HIGH
Image	SHARPNESS, GAMMA, MIRROR, FLIP, ACE, DEFOG, PRIVACY
Motion	OFF, ON
System	FRMAE RATE, FREQ, IMAGE RANGE, EX-SDI, LANGUAGE, RESET
Language	ENG, CHN, CHN(S), JPN, KOR
Operating Temp. /Storage Temp.	-10°C~+50°C(14°F~122°F) / -20°C~+60°C(-4°F~140°F)
Humidity	Less than 80% RH
Dimension(mm)	φ72x53