

24Hours Color Video Surveillance / Image Security Masking

Analog HD Bullet Camera

SNAH-SB21F



↓ Features

- 24Hours Color Video Surveillance
- 2M CMOS Sensor (Starvis)
- 1080P@30/25fps
- Analog-HD
- 4.0mm Ultra Bright Lens
(Option: 6.0mm Ultra Bright Lens)
- Defog Function (Visibility Enhancement)
- 3D Digital Noise Reduction
- Image Security Masking

↓ Dimension ※scale : NS (mm)

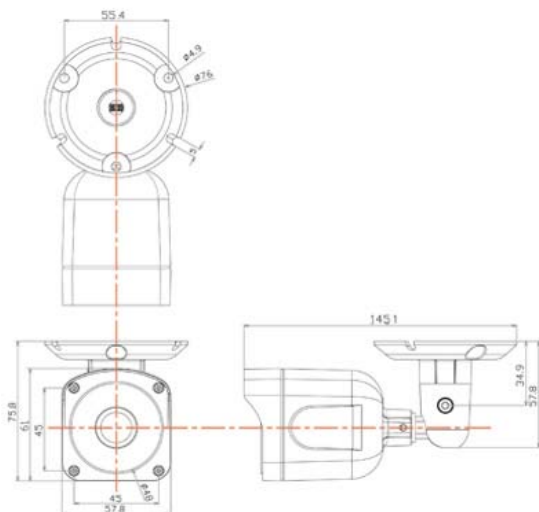

↓ Specifications

MODEL	SNAH-SB21F
Image Device	1/2.8" SONY 2M CMOS (Starvis)
Total Pixels	1945(H) x 1109(V) approx. 2.16M pixels
Effective Pixels	1945(V) x 1097(V) approx. 2.13M pixels
Scanning System	Progressive
Resolution	1080P@30/25fps
S/N Ratio	More than 52dB(AGC OFF)
Min.Illumination	0.001 Lux @ (SENSE-UP)
Video Output	Analog-HD
Electronic Shutter	NTSC : 1/30~1/30,000sec, PAL : 1/25~1/25,600sec
Lens Type	4.0mm Minimum illumination Fixed Lens (Option: 6.0mm Fixed Lens)
Iris	ELC, ALC
Exposure	BRIGHTNESS, SHUTTER, SENS-UP, AGC
Backlight	OFF, HLC, BLC, WDR
Day &Night	AUTO, COLOR, B&W
Color	AWB, COLOR GAIN
DNR	OFF, LOW, MIDDLE, HIGH
Image	SHARPNESS, GAMMA, MIRROR, FLIP, ACE, DEFOG, PRIVACY
Motion	OFF, ON
System	OUTPUT, FRAME RATE, FREQ, IMAGE RANGE, LANGUAGE, RESET
Language	ENG, CHN, CHN(S), JPN, KOR
Operating Temp. /Storage Temp.	-10°C~+50°C(14°F~122°F) / -20°C~+60°C(-4°F~140°F)
Humidity	Less than 80% RH
Dimension(mm)	145.1×55.4×75.8