

# AUTO FOCUS LENS

## 24Hours Color Video Surveillance / Image Security Masking



### A-HD Bullet Camera

#### SNAH-B6623A



#### Features

- 24Hours Color Video Surveillance
- 2M CMOS Sensor (Starvis)
- 1080P@30/25fps
- A-HD
- 2.7-12mm Motorized (Auto Focus) F1.4 Lens
- 2.8-12mm Motorized (Auto Focus) F1.4 Lens (Option)
- 2.7-10mm Motorized (Auto Focus) F1.2 Lens (Option)
- Defog Function (Visibility Enhancement)
- 3D Digital Noise Reduction
- Image Security Masking
- 1 point joint : 3axis adjustment

#### Dimension ※scale: NS (mm)

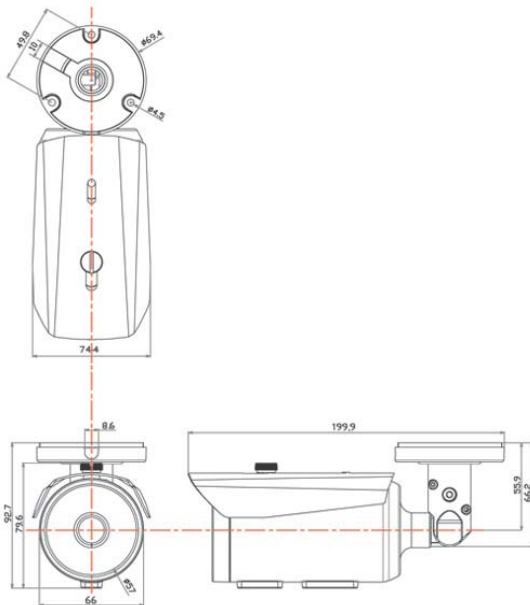

#### Specifications

MODEL	SNAH-B6623A
Image Device	1/2.8" SONY 2M CMOS (Starvis)
Total Pixels	1945(H) x 1109(V) approx. 2.16M pixels
Effective Pixels	1945(V) x 1097(V) approx. 2.13M pixels
Scanning System	Progressive
Resolution	1080P@30/25fps
S/N Ratio	More than 52dB(AGC OFF)
Min.Illumination	0.001 Lux @ (SENSE-UP)
Video Output	A-HD
Electronic Shutter	NTSC : 1/30~1/30,000sec, PAL : 1/25~1/25,600sec
Lens Type	2.7-12mm Motorized (Auto Focus) F1.4 Lens / 2.8-12mm Motorized (Auto Focus) F1.4 Lens (Option) / 2.7-10mm Motorized (Auto Focus) F1.2 Lens (Option)
Iris	ELC, ALC
2Motor	AF MODE, SCANNING, ONEPUSH AF, SYNC TDN, INITIAL
Exposure	BRIGHTNESS, SHUTTER, SENS-UP, AGC
Backlight	OFF, HLC, BLC, WDR
Day & Night	AUTO, COLOR, B&W
Color	AWB, COLOR GAIN
DNR	OFF, LOW, MIDDLE, HIGH
Image	SHARPNESS, GAMMA, MIRROR, FLIP, ACE, DEFOG, PRIVACY
Motion	OFF, ON
System	OUTPUT, FRAME RATE, FREQ, IMAGE RANGE, LANGUAGE, RESET
Language	ENG, CHN, CHN(S), JPN, KOR
Operating Temp. /Storage Temp.	-10°C~+50°C(14°F~122°F) / -20°C~+60°C(-4°F~140°F)
Humidity	Less than 80% RH
Dimension(mm)	199.9×92.7

#### 1 point joint : 3 axis adjustment

특허 (제 10-21130527호)



- Loosen one set screw to freely move the surveillance direction.  
It can be adjusted in any direction and can be easily installed by anyone.