

Image Security Masking

Hybrid (Analog HD / TVI / CVI / EX-SDI 1.0) IR Vandalproof Dome Camera

NHY-V1021VIR



Features

- 2M CMOS Sensor
- 1080P@30fps
- Analog HD / TVI / CVI / EX-SDI 1.0
- 2.8-12mm DC-IRIS Varifocal Lens
- Defog Function (Visibility Enhancement)
- 3D Digital Noise Reduction
- Image Security Masking
- 31 IR LEDs
- Camera Operating Indicate LED
(Normal: Green, Low Power : Red, Power Down: Off)

Dimension ※scale: NS (mm)

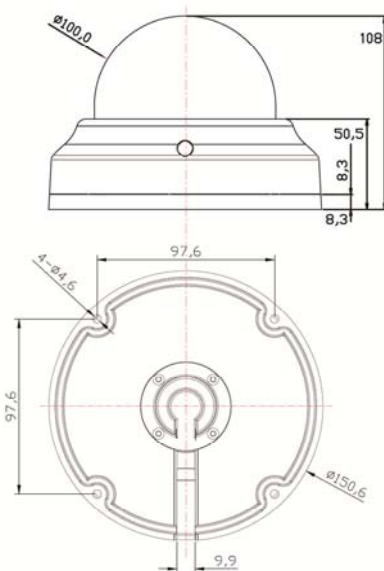

Dip Switch

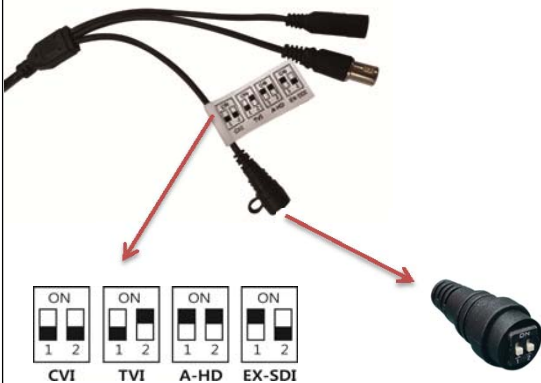

Specifications

MODEL	NHY-V1021VIR
Image Device	1/2.9" SONY 2M CMOS
Total Pixels	2001(H) x 1121(V) approx. 2.24M pixels
Effective Pixels	1985(V) x 1105(V) approx. 2.19M pixels
Resolution	1080P@30fps
S/N Ratio	More than 52dB(AGC OFF)
Min.Illumination	0.0 Lux @ (IR ON)
Video Output	Analog HD / TVI / CVI / EX-SDI 1.0
Sync. System	Internal
Electronic Shutter	NTSC : 1/30~1/30,000sec, PAL : 1/25~1/25,600sec
Lens Type	2.8-12mm DC-IRIS Varifocal Lens
Iris	ELC, ALC
Exposure	BRIGHTNESS, SHUTTER, SENS-UP, AGC
Backlight	OFF, HLC, BLC, WDR
Day & Night	AUTO, COLOR, B&W
Color	AWB, COLOR GAIN
DNR	OFF, LOW, MIDDLE, HIGH
Image	SHARPNESS, GAMMA, MIRROR, FLIP, ACE, DEFOG, PRIVACY
Motion	OFF, ON
System	OUTPUT, FRAME RATE, FREQ, IMAGE RANGE, LANGUAGE, RESET
Language	ENG, CHN, CHN(S), JPN, KOR
IR LED(Wavelength)	31 IR LEDs (850nm)
Operating Temp. /Storage Temp.	-10°C~+50°C(14°F~122°F) / -20°C~+60°C(-4°F~140°F)
Humidity	Less than 80% RH
Power Consumption	DC12V(±10%), MAX. mA
Dimension(mm)	Ø150.5x108