

Image Security Masking

Hybrid (Analog HD / TVI / CVI / EX-SDI 1.0) IR Bullet Camera

NHY-B6621FIR



Features

- 2M CMOS Sensor
- 1080P@30fps
- Analog HD / TVI / CVI / EX-SDI 1.0
- 3.6mm Fixed Lens
- Defog Function (Visibility Enhancement)
- 3D Digital Noise Reduction
- Image Security Masking
- 45 IR LEDs
- Camera Operating Indicate LED
(Normal: Green, Low Power : Red, Power Down: Off)
- 1point joint : 3axis adjustment

Dimension ※scale: NS (mm)

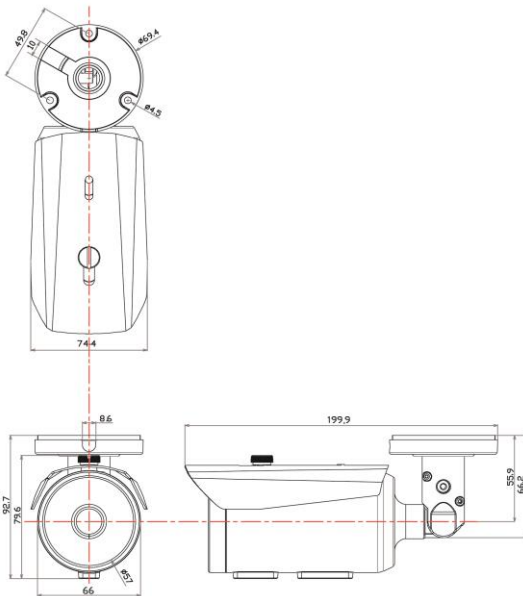

Specifications

MODEL	NHY-B6621FIR
Image Device	1/2.9" SONY 2M CMOS
Total Pixels	2001(H) x 1121(V) approx. 2.24M pixels
Effective Pixels	1985(V) x 1105(V) approx. 2.19M pixels
Resolution	1080P@30fps
S/N Ratio	More than 52dB(AGC OFF)
Min.Illumination	0.0 Lux @ (IR ON)
Video Output	Analog HD / TVI / CVI / EX-SDI 1.0
Sync. System	Internal
Electronic Shutter	NTSC : 1/30~1/30,000sec, PAL : 1/25~1/25,600sec
Lens Type	3.6mm Fixed Lens
Iris	ELC, ALC
Exposure	BRIGHTNESS, SHUTTER, SENS-UP, AGC
Backlight	OFF, HLC, BLC, WDR
Day & Night	AUTO, COLOR, B&W,EXTERN
Color	AWB, COLOR GAIN
3D-DNR	OFF, LOW, MIDDLE, HIGH
Image	SHARPNESS, GAMMA, MIRROR, FLIP, ACE, DEFOG, PRIVACY
Motion	OFF, ON
System	OUTPUT, FRAME RATE, FREQ, IMAGE RANGE, LANGUAGE, RESET
Language	ENG, CHN, CHN(S), JPN, KOR
IR LED(Wavelength)	45 IR LEDs (850nm)
Operating Temp. /Storage Temp.	-10°C~+50°C(14°F~122°F) / -20°C~+60°C(-4°F~140°F)
Humidity	Less than 80% RH
Power Consumption	DC12V(±10%), MAX. mA
Dimension(mm)	199.9×92.7

1 point joint : 3axis adjustment



- Loosen one set screw to freely move the surveillance direction
- It can be adjusted in any direction and can be easily installed by anyone.

Dip Switch

