

Smart Auto Tracking / Image Security Masking

Analog-HD IR Vandalproof Dome Camera

SNAH-V1021VIR



Features

- 2M CMOS Sensor (Starvis)
- 1080P@30/25fps
- Analog-HD
- 2.8-12mm TDN DC-IRIS Varifocal Lens
- Defog Function (Visibility Enhancement)
- 3D Digital Noise Reduction
- Smart Auto Tracking(SAT)
- Image Security Masking
- 31 IR LEDs
- Camera Operating Indicate LED
(Normal: Green, Low Power: Red, Power Down:Off)

Dimension ※scale : NS (mm)

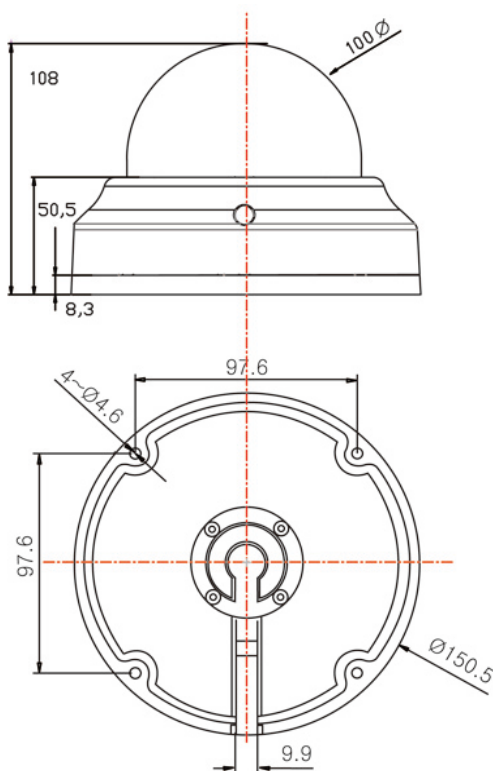

Specifications

MODEL	SNAH-V1021VIR
Image Device	1/2.8" SONY 2M CMOS (Starvis)
Total Pixels	1945(H) x 1109(V) approx. 2.16M pixels
Effective Pixels	1945(V) x 1097(V) approx. 2.13M pixels
Scanning System	Progressive
Resolution	1080P@30/25fps
S/N Ratio	More than 52dB(AGC OFF)
Min.Illumination	0.0 Lux @ (IR ON)
Video Output	Analog-HD
Electronic Shutter	NTSC : 1/30~1/30,000sec, PAL : 1/25~1/25,600sec
Lens Type	2.8-12mm DC-IRIS Varifocal Lens
Iris	ELC, ALC
Exposure	BRIGHTNESS, SHUTTER, SENS-UP, AGC
Backlight	OFF, HLC, BLC, WDR
Day & Night	AUTO, COLOR, B&W, EXTERN
Color	AWB, COLOR GAIN
DNR	OFF, LOW, MIDDLE, HIGH
Image	SHARPNESS, GAMMA, MIRROR, FLIP, D-ZOOM, ACE, DEFOG, SHARDING, PRIVACY
SAT (Smart Auto Tracking)	OFF, ON
System	OUTPUT, IMAGE RANGE, LANGUAGE, RESET
Language	ENG, CHN, CHN(S), JPN, KOR
IR LED(Wavelength)	31 IR LEDs(850nm)
Operating Temp. /Storage Temp.	-10°C~+50°C(14°F~122°F) / -20°C~+60°C(-4°F~140°F)
Humidity	Less than 80% RH
Dimension(mm)	Ø150.6x108