

Multi-View Camera

SVDMW-1123AHD



↓ Features

- 2Mega CMOS Sensor x 3ea (Starvis)
- 1080P(30fps)
- Analog HD
- 3.6mm Fixed Lens x 3ea
(Option 2.5/3.6/6.0/8.0mm)
- Weatherproof

↓ Dimension ※scale : NS (mm)

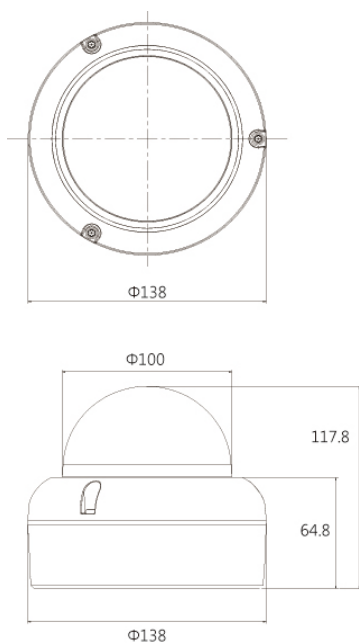

↓ Specifications

| | |
|-----------------------|--|
| Model | SVDMW-1123AHD |
| TV System | DIGITAL / Analog HD |
| Image Sensor | 1/2.9" 2M CMOS Sensor x 3ea |
| Total Pixels | 1956(H) x 1266(V) approx. 2.47M pixels |
| Scanning System | PROGRESSIVE |
| Sync. Mode | INTERNAL |
| Resolution | more 1000 TV Lines |
| Video Output | Analog HD |
| White Balance | ATW/AWB/AWC->SET/INDOOR/OUTDOOR/MANUAL |
| Shutter Speed | MANUAL/AUTO/FLK |
| LENS | 3.6mm Fixed Lens x 3ea (Option 2.5/3.6/6.0/8.0mm) |
| On Screen Display | Built-In |
| Display Mode | Full Screen, PIP, Split Screen mode available |
| Video Adjustment | Brightness, Sharpness, Contrast |
| Remote Control | Infrared Remote Controller |
| RS 485 Control | Pelco-D |
| Video Output Terminal | BNC Connector |
| Power Input Terminal | Φ 5.5 Jack |
| Operation Temperature | -10°C ~50°C (14°F ~ 122°F) |
| Power Consumption | DC 12V(±10%), (Max. 8Watts) |
| Dimension(mm) | Φ138 x 117.8 |