

Multi-View Camera

# SQCAM-IR99AHD



### ↓ Features

- 2Mega CMOS Sensor x 3ea (Starvis)
- 1080P(30fps)
- Analog HD
- Main : 2.5mm, 16mm Fixed Lens  
Sub: 3.6mm Fixed Lens
- Weatherproof

### ↓ Dimension ※scale : NS (mm)

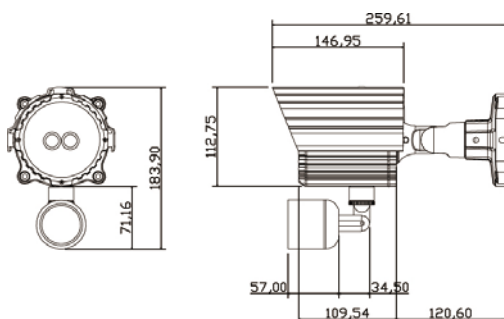

### ↓ Specifications

Model	SQCAM-IR99AHD
TV System	DIGITAL / Analog HD
Image Sensor	1/2.8" 2M CMOS Sensor x 3ea
Total Pixels	1945(H) x 1109(V) approx. 2.16M pixels
Scanning System	PROGRESSIVE
Sync. Mode	INTERNAL
Resolution	more 1000 TV Lines
Video Output	Analog HD
White Balance	ATW/AWB/AWC-> SET/INDOOR/OUTDOOR/MANUAL
Shutter Speed	MANUAL/AUTO/FLK
LENS	Main : 2.5mm, 16mm Fixed Lens Sub: 3.6mm Fixed Lens
On Screen Display	Built-In
Display Mode	Full Screen, PIP, Split Screen mode available
Video Adjustment	Brightness, Sharpness, Contrast
Remote Control	Infrared Remote Controller
RS 485 Control	Pelco-D
Video Output Terminal	BNC Connector
Power Input Terminal	Φ 5.5 Jack
Operation Temperature	-10°C ~50°C (14°F ~ 122°F)
Power Consumption	DC 12V(±10%), (Max. 7.2Watts)
Dimension(mm)	146.9 x 183.9