

Multi-View Camera

SDMWI-1123EX



Features

- 2Mega CMOS Sensor x 3ea (Starvis)
- 1080P(30fps)
- EX-SDI(2.0/1.0), HD-SDI
- 3.6mm Fixed Lens x 3ea

Dimension ※scale : NS (mm)

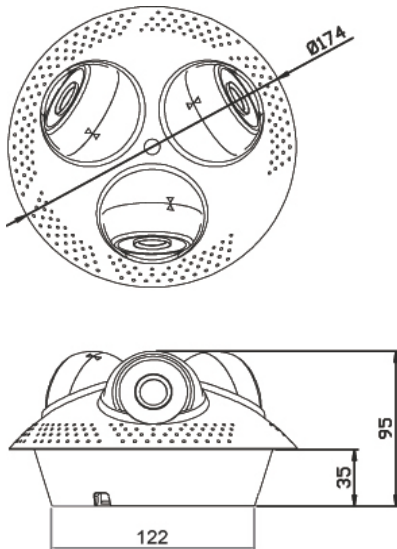

Specifications

Model	SDMWI-1123EX
TV System	DIGITAL / EX-SDI
Image Sensor	1/3" 2M CMOS Sensor x 3ea
Total Pixels	1945(H) x 1109(V) approx. 2.15M pixels
Scanning System	PROGRESSIVE
Sync. Mode	INTERNAL
Resolution	more 1000 TV Lines
Video Output	EX-SDI(2.0/1.0), HD-SDI
White Balance	ATW/AWB/AWC->SET/INDOOR/OUTDOOR/MANUAL
Shutter Speed	MANUAL/AUTO/FLK
LENS	3.6mm Fixed Lens x 3ea
On Screen Display	Built-In
Display Mode	Full Screen, PIP, Split Screen mode available
Video Adjustment	Brightness, Sharpness, Contrast
Remote Control	Infrared Remote Controller
RS 485 Control	Pelco-D
Video Output Terminal	BNC Connector
Power Input Terminal	Φ 5.5 Jack
Operation Temperature	-10°C ~50°C (14°F ~ 122°F)
Power Consumption	DC 12V(±10%), (Max. 13Watts)
Dimension(mm)	Φ174x 95