

Image Security Masking

Analog-HD IR Dome Camera

NAH-D8027FIR



Features

- 2M CMOS Sensor
- 1080P @30/25fps
- Analog-HD / TVI
- 3.6mm Fixed Lens
- Defog Function (Visibility Enhancement)
- 3D Digital Noise Reduction
- Image Security Masking
- 22 IR LEDs
- Camera Operating Indicate LED
(Normal: Green, Low Power: Red, Power Down: Off)

Dimension ※scale: NS (mm)

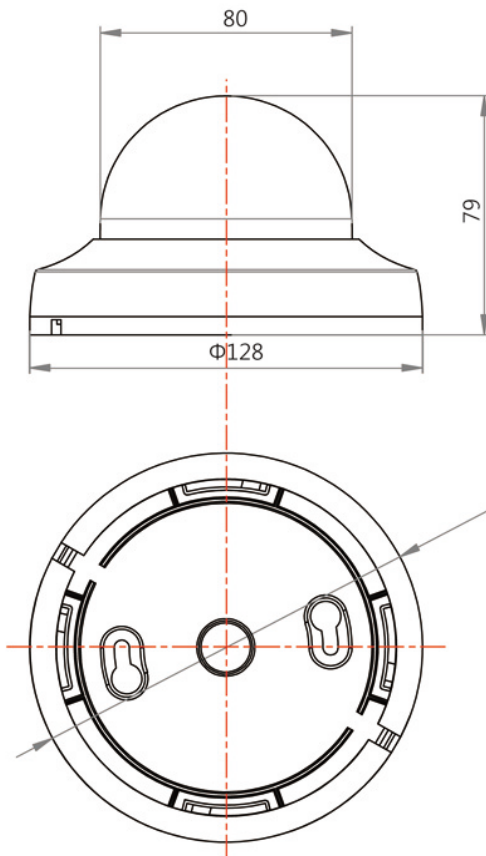

Specifications

MODEL	NAH-D8027FIR
Image Device	1/2.9" SONY 2M CMOS
Total Pixels	2001(H) x 1121(V) approx. 2.24M pixels
Effective Pixels	1985(V) x 1105(V) approx. 2.19M pixels
Scanning System	Progressive
Resolution	1080P@30/25fps
S/N Ratio	More than 52dB(AGC OFF)
Min.Illumination	0.0 Lux @ (IR ON)
Video Output	Analog-HD / TVI
Electronic Shutter	NTSC : 1/30~1/30,000sec, PAL : 1/25~1/25,600sec
Lens Type	3.6mm Fixed Lens
Iris	ELC, ALC
Exposure	BRIGHTNESS, SHUTTER, SENS-UP, AGC
Backlight	OFF, HLC, BLC, WDR
Day & Night	AUTO, COLOR, B&W, EXTERN
Color	AWB, COLOR GAIN
DNR	OFF, LOW, MIDDLE, HIGH
Image	SHARPNESS, GAMMA, MIRROR, FLIP, ACE, DEFOG, PRIVACY
Motion	OFF, ON
System	OUTPUT, FRAME RATE, FREQ, IMAGE RANGE, LANGUAGE, RESET
Language	ENG, CHN, CHN(S), JPN, KOR
IR LED(Wavelength)	22 IR LEDs (850nm)
Operating Temp. /Storage Temp.	-10°C~+50°C(14°F~122°F) / -20°C~+60°C(-4°F~140°F)
Humidity	Less than 80% RH
Dimension(mm)	Φ128x79