

Super Wide Angle(152 °) Lens / Image Security Masking

Analog-HD Mini Dome Camera

NAH-D6021F



↓ Features

- 2M CMOS Sensor
- 1080P @30/25fps
- Analog-HD / TVI
- 2.5mm wide Angle Fixed Lens
- Defog Function (Visibility Enhancement)
- 3D Digital Noise Reduction
- Image Security Masking

↓ Dimension ※scale: NS (mm)

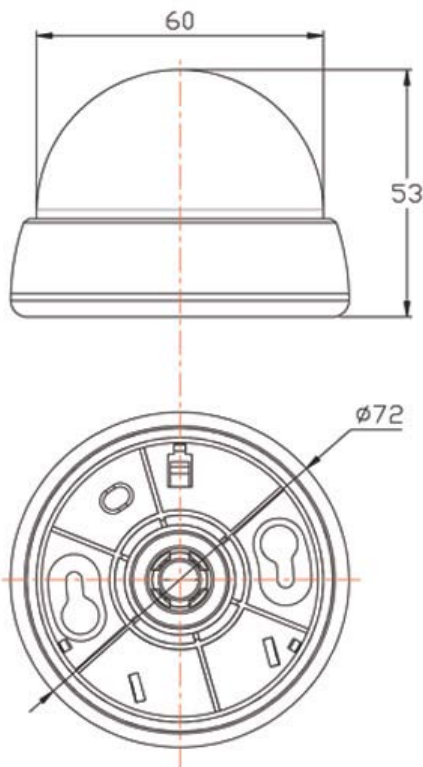

↓ Specifications

MODEL	NAH-D6021F
Image Device	1/2.9" SONY 2M CMOS
Total Pixels	2001(H) x 1121(V) approx. 2.24M pixels
Effective Pixels	1985(V) x 1105(V) approx. 2.19M pixels
Scanning System	Progressive
Resolution	1080P@30/25fps
S/N Ratio	More than 52dB(AGC OFF)
Min.Illumination	0.001 Lux @ (SENSE-UP)
Video Output	Analog-HD / TVI
Electronic Shutter	NTSC : 1/30~1/30,000sec, PAL : 1/25~1/25,600sec
Lens Type	2.5mm Super Wide Angle(152°) Fixed Lens
Iris	ELC, ALC
Exposure	BRIGHTNESS, SHUTTER, SENS-UP, AGC
Backlight	OFF, HLC, BLC, WDR
Day & Night	AUTO, COLOR, B&W
Color	AWB, COLOR GAIN
DNR	OFF, LOW, MIDDLE, HIGH
Image	SHARPNESS, GAMMA, MIRROR, FLIP, ACE, DEFOG, PRIVACY
Motion	OFF, ON
System	OUTPUT, FRAME RATE, FREQ, IMAGE RANGE, LANGUAGE, RESET
Language	ENG, CHN, CHN(S), JPN, KOR
Operating Temp. /Storage Temp.	-10°C~+50°C(14°F~122°F) / -20°C~+60°C(-4°F~140°F)
Humidity	Less than 80% RH
Dimension(mm)	Ø72x53